



UL Approved Natural Gas Detector Fixed Combustible LPG Gas Analyzer

Our Product Introduction

for more products please visit us on multi-gasdetection.com

Basic Information

- Place of Origin: Nanjing, China
- Brand Name: KELISAIKE
- Certification: CE & UL & EMC
- Model Number: K800
- Minimum Order Quantity: 1PC
- Price: USD 150-500/PC
- Packaging Details: Carton
- Delivery Time: 7 work days
- Stock: 1PC
- Payment Terms: T/T, Western Union, MoneyGram, Paypal



Product Specification

- Model NO: K800
- Gas: O₂, CO, CO₂, LEL, H₂S, Etc
- Signal Output: 4 To 20mA
- Voltage: DC 24V
- Alarm Type: Vibration Alarm With Light, Sound
- Explosion-Proof Grade: Exd Iict6
- Operating Temperature: -20 ~+50
- Weight: 1.8kg
- Warranty: 1 Year
- HS Code: 8531100000
- Trademark: KELISAIKE
- Origin: Nanjing, China
- Highlight: **Natural Gas Fixed Gas Detector, UL Approved Fixed Gas Detector, Combustible LPG Fixed Gas Detector**



More Images



UL Approved Natural Gas Detector Fixed Combustible LPG Gas Detector



The **K800 Series Fixed Gas Detector** provides comprehensive monitoring of combustible, toxic gas hazards in potentially explosive atmospheres, indoors and outdoors-and is marked by installation ease and flexibility, user-friendly operation and cost-effective gas monitoring.

Application:

The detector working with gas controller are widely used to detect gas in refinery, chemical plant, LPG station, boiler room, painting plant and other places with gas exists, effectively protect personnel and plant from flammable, toxic and oxygen hazards.

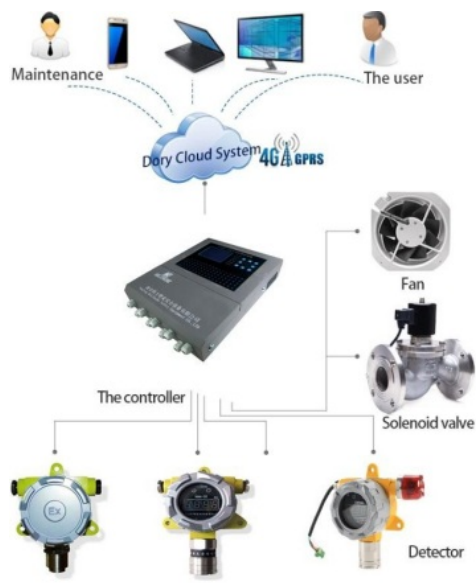

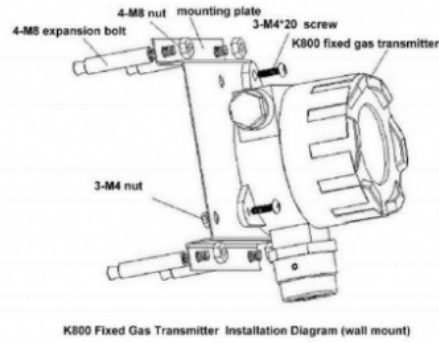
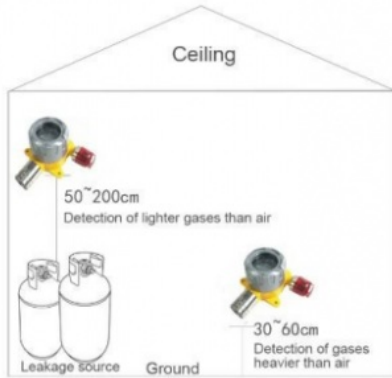
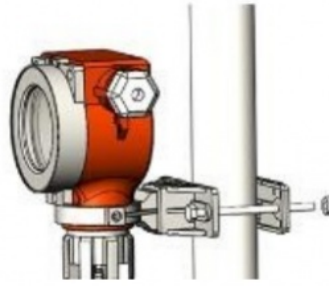
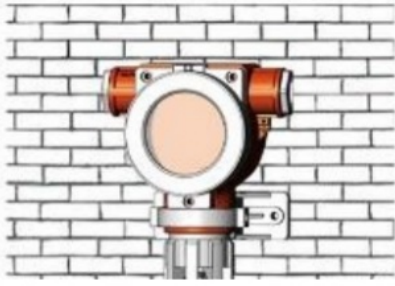

Key Features:

- 1) Providing digital LCD displayer, alarm facility with sound and light, and solid relay output on the spot, allowing control of the equipments easily.
- 2) Supporting 4 to 20mA analog signal output (DC24V), connecting with the remote host controller, and having direct access to the DCS.
- 3) Connecting 3-core shield cable, 3x1.0mm.
- 4) Special transmitter mounting kit making the installation and performing calibration easier and better.
- 5) Ambient temperature: -20°C~50°C
- 6) Explosion-proof grade: Ex d IIC T6
- 7) High sensitivity, short response time and good stabilization

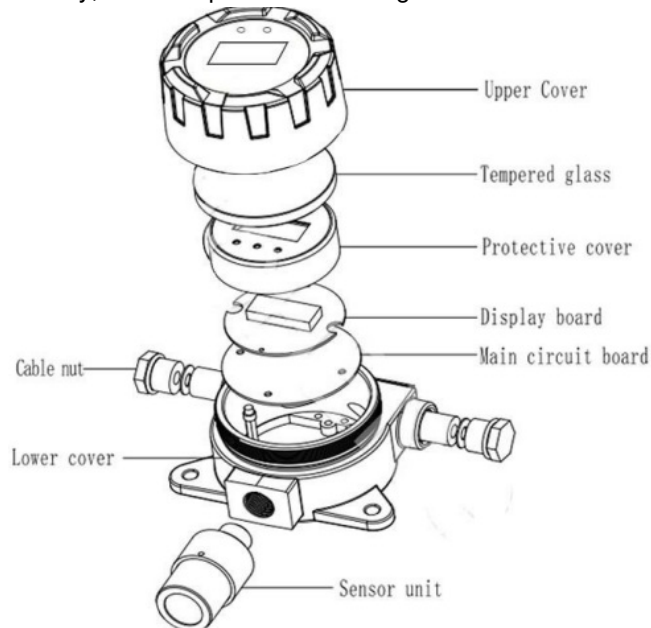

Parameter:

Item:	K800 Fixed gas detector
Sensor Cell:	UK sensors (brand CITY, Alphasense, Dynament etc.), US (brand Honeywell), Japan and Germany sensors
Lifetime of Detector:	2 - 5 years

Sample Mode	Diffusion
Output Signals:	4-20mA&RS485
Operating Voltage:	24V DC
Response Time	T90≤30S
Suitable Cable	RVVP3*1.5mm2 cable
Wiring	3-wire/4-wire
Relay Output	1 relay output
Operation Method	with remote control
Ingress Protection	IP66
Body Material	YL113 aluminum +304L S/S
Display	4 digital LED readout display (LCD display with power, fault,alarm-1,alarm-2 indicator light)
Transmission Cable	Three core shield cable, 3×1.5mm
Ambient Temperature:	- 20 ° C ~ + 50 ° C
Relative Humidity:	10~90%RH(non condensation)
Working Pressure:	86~106Kpa
Detection Precision:	±5%FS
Net Weight:	K800-N: 1.6kg K800-DA:2 kg
Dimension(mm):	183×143×107mm
Certificates	EN 61326-1:2013; EX (Exd IICT6 Gb;Ex tD A21IP66T80°C); SIL(SIL2); UL 508 UL1203
Explosion-proof Grade:	Exd II CT6
Protection Grade:	IP65

Certificates:



CE Certificate



UL Certificate



UL Certificate

Imported Sensors:

Honeywell & Alphasense & CITY



COMMONLY USED GAS DETECTION LIST

Gas Type	Detection Method	Detection Range	Operating temperature	Resolution	T90 Response Time
O2	Electrochem	0-25%vol/30%vol	-30 ~+60	0.1%vol	T90≤20s
CO	Electrochem	0-100ppm/500ppm/2000ppm	-30 ~+60	0.1ppm	T90≤20s
H2S	Electrochem	0-100ppm/200ppm/1000ppm	-30 ~+60	0.1ppm	T90≤30s
NO2	Electrochem	0-10ppm/30ppm/100ppm	-30 ~+60	0.1ppm	T90≤30s
NO	Electrochem	0-100ppm/200ppm/1000ppm	-30 ~+60	0.1ppm	T90≤50s
CL2	Electrochem	0-20ppm	-30 ~+60	0.1ppm	T90≤30s
H2	Electrochem	0-2000ppm/4%vol	-30 ~+60	0.1ppm	T90≤30s
SO2	Electrochem	0-200ppm	-30 ~+60	0.1ppm	T90≤30s
CL2	Electrochem	0-20ppm	-30 ~+60	0.1ppm	T90≤30s
HCL	Electrochem	0-30ppm/200ppm	-30 ~+60	0.1ppm	T90≤30s
HCN	Electrochem	0-10ppm/200ppm	-30 ~+60	0.1ppm	T90≤30s
NH3	Electrochem	0-100ppm/500ppm/1000ppm	-30 ~+60	0.1ppm	T90≤25s
O3	Electrochem	0-1ppm/10ppm	-30 ~+60	0.1ppm	T90≤30s
PH3	Electrochem	0-5ppm/10ppm	-30 ~+60	0.1ppm	T90≤30s
CLO2	Electrochem	0-3ppm	-30 ~+60	0.1ppm	T90≤50s
H2	Catalytic	100%lel	-40 ~+60	1%lel	T90≤20s
CH4(CA)	Catalytic	0-100%lel	-40 ~+60	1%lel	T90≤20s
CH4(IR)	IR	0-5%vol/100%vol	-40 ~+60	0.1%vol	T90≤20s
VOCs	PID	0-50ppm/200ppm/1000ppm/5000ppm	-40 ~+60	0.1ppm	T90≤20s
CO2(IR)	IR	0-5%vol/100%vol	-40 ~+60	0.01%vol	T90≤20s
C3H8(IR)	IR	0-2%vol/100%vol	-40 ~+60	0.01%vol	T90≤20s
CxHy(IR)	IR	0-100%lel	-40 ~+60	1%lel	T90≤20s
SF6(IR)	IR	0-1000ppm/2000ppm	-40 ~+60	1ppm	T90≤20s



COMPANY
APPEARANCE

THE OFFICE
MEETING



WORKSHOP
INSTRUMENT



- Nanjing Kelisaik Safety Equipment Co., Ltd. founded in 2004, Nanjing Kelisaik has three subsidiaries in Beijing, Xi'an and Xinjiang province, and over 30 domestic sales service centers.
- Standard products include the K60 series portable single gas detectors, K60-IV series multi gas detectors, K800 series fixed gas transmitters, K500 series wall-mounted gas detectors, K1000 series gas detector control panel units, KL99 series air breathing apparatuses, etc.
- Nanjing Kelisaik is also a factory with rich experience in OEM service, providing professional design and manufacturing of customized products.



» Our Certificates



We have obtained CE, ISO and other international certificates for different market requirements.

» Product Application Show



- The company's products are widely used in fields of petroleum, chemical, gas transmission and distribution, warehousing, municipal gas supply, fire fighting, environmental protection, metallurgy, pharmacy, energy and power industry.

Why Choose Us?

1. Mutual benefit :We are a factory. The price is much more competitive than others in the same quality.
2. Professional engineers:With 20+ years history, KELISAIKE has a professional engineering team: 4 engineers who have more than 20 years' experience and over 5 engineer assistants in gas detection line, with Hi-Tech manufacturing equipments, we make more accurate and stable products.
3. Customize : We have strong R&D team, the custom product as your request are available.
4. Free OEM service : (a) Silk-printing your Logo(z100PCS). (b) Design your color box(z500PCS).
5. Mix order: We accept mix order, different model and small quantity order.
6. After service: (a) 1 Year warranty. (b) If there's any inferior-quality products are found, new ones could be sent to replace at free cost in the next order after confirmation.

Our Service:

1. For all our customers, our products have 1 year warranty, and life-long maintenance.
2. All inquiries will be replied in 24 hours.
3. Providing technical support, professional engineers are specialized in dealing with gas monitoring problems you met.
4. OEM and ODM service are welcome.
5. KELISAIKE plant is located in Nanjing, only 1 hour by high speed train from Shanghai. Welcome to visit the factory.
6. All products are well tested and packed before shipment; the certificate of inspection will be provided.

FAQ

Q: Can I order one piece for sample to test the quality?

A: Yes, We recommend to check the sample before place an qty order.

Q: May I have your catalogue and price list for trial order in MOQ quantity?

A: All our products were shown on -line, please have a detailed looking and choose the interested models in our

site. Oryou can send email to us.

Q: If I order big quantity, what's the good price?

A: Please send the details enquiry to us, such as the Item Number, Quantity for each item, Quality request, Logo, Payment Terms, Transport method, Discharge place etc. We will make the accurate quotation to you as soon as possible.



Nanjing Kelisaik Safety Equipment Co., Ltd.



+86 25 8719 3262



manager@njklsk.cn



multi-gasdetection.com

Bldg 12, 2 Qingshuiting West Road, Nanjing, Jiangsu, China, 211102